

30x30x10mm

■ Model B

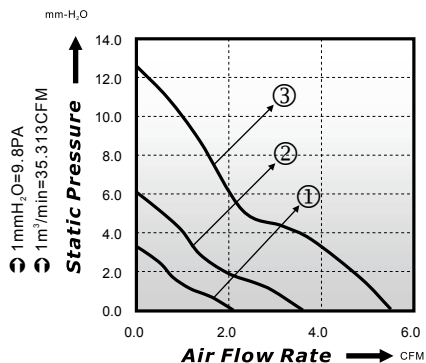

■ P-Q Curve (At Rated Voltage)



■ Dimensions Drawing

Unit: (mm)

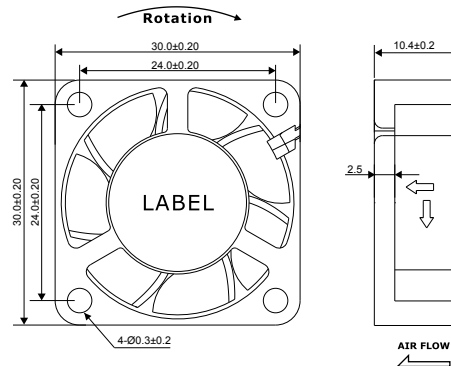

Model No	Bearing (*)	Rated Voltage (VDC)	Rated Current (A)	Power Consumption (Watts)	Speed (rpm)	Air Flow (CFM)	Static Pressure (mmH ₂ O)	Noise (dBA)	Curve
ED03010-05L*	○ ● ⊖	5	0.11	0.55	6000	2.1	3.3	17.6	1
ED03010-05M*	○ ● ⊖	5	0.14	0.70	10000	3.6	6.1	28.5	2
ED03010-05H*	○ ● ⊖	5	0.24	1.20	15400	5.5	12.6	38.0	3
ED03010-12L*	○ ● ⊖	12	0.046	0.55	6000	2.1	3.3	17.6	1
ED03010-12M*	○ ● ⊖	12	0.06	0.72	10000	3.6	6.1	28.5	2
ED03010-12H*	○ ● ⊖	12	0.10	1.20	15400	5.5	12.6	38.0	3

* Bearing Type: ○ Sleeve ● Two Ball ⊖ Hydro-Dynamic